



VACUUM

WEV-670 OWNER'S MANUAL

TABLE OF CONTENTS

INTRODUCTION.....	1
WEV-670 SPECIFICATIONS.....	2
UNPACKING AND CHECKING CONTENTS	3
SAFETY PRECAUTIONS.....	3
PREVENTATIVE SAFETY MEASURES	3
PERSONNEL SELECTION AND QUALIFICATION	3
SAFETY: OPERATION OF MACHINE	3
ELECTRICAL SAFETY	4
POWER CORDS	4
USING A GENERATOR.....	4
SAFETY REGARDING MAINTENANCE	4
MANUAL TRANSPORT.....	4
TRANSPORTING INSIDE VEHICLES	4
OPERATING PRECAUTIONS.....	4
OPERATING INSTRUCTIONS	4
PULSE CONTROLLER.....	5
COMPRESSOR.....	5
WEV-670 VAC BREAKOUT.....	6
WEV-670 MACHINE BREAKOUT.....	7
DUST TANK	8
INTAKE SETUP	9
POWER SETUP	10
DUST VAC CLEAN SETTINGS	11
COMPRESSOR	12
COMPRESSOR PRESSURE	13
WIRING SCHEMATIC.....	14
WARRANTY.....	15
CONTACT INFORMATION.....	15

INTRODUCTION

The WEV-670 is top of the line in commercial vacuums and dust recovery equipment. Utilizing this manual will help you to get familiar with the operation, proper use, and getting the most from your new purchase.

The WEV-670 Vacuum is shipped free from defects; however an initial inspection should be made to ensure that no damage has occurred during shipping. Safety is paramount when operating any machinery. Safety is a combination of common sense and staying alert when operating industrial equipment. Read this operator's manual and understand it. The following safety rules should be observed when operating the vacuum.

Safety Signal Words used in this Manual and their meaning are as follows:

DANGER: Means if the safety information is not followed, it is likely that the operator or by-standers risk of being seriously injured or killed is very high.

WARNING: Means if the safety information is not followed, the operator or bystanders could be seriously injured or killed.

CAUTION: Means if the safety information is not followed the operator, or by-stander may be injured or the vacuum machine maybe damaged

WARNING: Preventing electrical shock. To reduce the risk of fire, electrical shock, or injury, read and understand the owners' manual before operating. The WEV-670 is designed to vacuum dry material only. Never use the machine to vacuum liquids of any kind.

CAUTION: Reducing static shock. Static Shocks are common and occur in dry areas or when the relative humidity of the air is low. Be aware of low humidity conditions and if static shocks are persistent, use a static reduction vacuum hose to reduce static shock.

CAUTION: Proper Extension cord use. It is very important to use the proper extension cord with power tools, the performance and life of the equipment depend on it. Using an improper extension cord can cause the equipment to malfunction and become damaged. It can also cause harm to the operator. The proper cord size to use with this machine is 3 phase 240V.

WEV-670 SPECIFICATIONS

WEV-670 Technical Specifications

power	7.5 KW 10 HP
voltage	3 phase 220V
ampere	16A-20A
max airflow	600m ³ /H
sound	60db
cfm	1045 air watts
lift	140 air watts
suction size (inches)	2-4"
motor safety grade	IP54
dimensions (inches)	51", 39", 69"
weight	506 LBS

PERSONAL PROTECTION It's always recommended to wear the appropriate Personal Protective Equipment (PPE) for the task at hand and follow your employer's safety policy. Commonly known PPE such as safety glasses, gloves, earplugs, respirators, ect . . . are recommended as needed. For further information on OSHA requirements, visit <https://www.osha.gov/Publications/osha3151.pdf>

UNPACKING & CHECKING CONTENTS

- Remove the vacuum and all the contents from packaging. Check each item against the packing list.
- If any items are damaged or missing, or if additional assistance is needed, contact Warrior Equipment 1-877-743-9732

SAFETY PRECAUTIONS

- All Warrior Equipment machines, if not used according to the regulations, may be hazardous for operating, for bystanders, any property, and the operator.
- The operating authority is responsible for compliance with the safety regulations during operation, maintenance, and for the use of all safety devices supplied with the machine, as well as the provision of any additional safety devices.
- Eye and hearing protection must be worn at all times.
- Never operate the machine when it's not in its upright position.

PREVENTIVE SAFETY MEASURES

- Keep the user guide near the location where the machine is being operated and must be within reach at all times.
- General and legal regulations regarding accident prevention and environmental protection must be complied with as per local regulations. For example, the handling of hazardous substances, or to the provision and wearing of personal protection equipment, as well as compliance with traffic regulations.
- The user guide is not the only safety instructions that are to be followed. It must be supplemented by other instructions, including the duty to supervise and report incidents relating to particular working practices, work organization, work procedures, and personnel safety.
- Personnel entrusted with working with the machine must read the User Guide before starting work, in particular the "Safety Regulations" chapter. To read these instructions after work is started is too late. This applies to incidental activities such as setting up of the equipment, carrying out maintenance work, or training staff to work with the machine.
- From time to time the working practices of the operators are advised to be checked by a supervisor especially to the items regarding awareness of safety and hazards.
- Eye and hearing protection must be worn at all times.
- Use personal protection equipment that is necessary or required by local regulations. Take notice of all safety and hazard notices of the machines.

PERSONNEL SELECTION AND QUALIFICATION

- Any work or modifications on the machine may only be undertaken by trained personnel.
- Specify clearly the responsibilities of personnel for operation, setting up, servicing and maintenance work.
- Only trained and authorized personnel may operate or work on the machine.
- Define responsibilities of the machine operator, with regard to traffic safety regulations, and inform him/her, not to take instructions from third parties who may not be complying with the local safety requirements.
- Personnel, who are being trained to operate equipment, may only use the machine under constant supervision of an experienced person authorized for training.
- Work on electrical equipment may only be undertaken by a skilled electrician or by trained persons under the supervision of a skilled electrician in accordance with the local electrical engineering regulations.

SAFETY: OPERATION OF MACHINE

- Never permit any method of working that impairs safety.
- Recognized official procedures must be used to ensure the machine is only operated in safe and best conditions.
- Only operate the machine when all safety devices and related safety equipment are present and operational.
- Check the machine visually for any damage and defects at least once a day and prior to each use.
- In the event of operational malfunctions, the machine must be shut down immediately and secured. Secure the work area around the machine in public areas providing a safe distance of at least 10'x10' area around the machine.
- Carry out the switch on, and switch off operations in accordance with this user guide.
- Before switching on the machine, make sure that no-one can be endangered when the machine starts up.
- Never operate the machine when not in its upright position.
- All persons in the proximity of the machine must wear hearing and eye protection as well as safety shoes.
- Only use power cords which are sized and marked in accordance with the overall power consumption of the machine and the valid VDE and OSHA guidelines.

ELECTRICAL SAFETY

- The power source must be equipped with proper breakers and/or fuses. All cords used must be marked and rated according to the local legal laws. Consult with OSHA or other regulatory agencies requirements before operation .
- Never connect the machine to a power source that does not provide a protective ground.
- Work on electrical equipment may only be undertaken by a skilled electrician or by trained persons under the supervision of a skilled electrician as well as in accordance with the local electrical engineering regulations.
- Use only extension cords which are sized and marked in accordance with the overall power consumption of the machine and the valid VDE and OSHA guidelines.
- The electrical equipment to be used must be inspected regularly. Defects such as loose connections or scorched cords must be rectified immediately before use of equipment. Call a skilled electrician or our customer services if you have any uncertainties.

POWER CORDS

- Only use cords which are marked and rated according to the specifications.

USING A GENERATOR

- The generator must be equipped with protective ground and operated in accordance with the current EN-VDE directives (this applies to the protective ground conductor in particular) in order to ensure that all safety devices are functioning and eliminate possible damage to electrical components.

SAFETY REGARDING MAINTENANCE

- Set the machine into the OFF position before beginning any work on the machine.
- Never work on the machine while power is still connected. Ensure all parts have come to a complete stop before performing any work.
- Any adjustment, servicing, and inspection work specified in this User Guide or elsewhere, or any information on the replacement of parts and equipment must be undertaken and/or complied with.
- These activities may only be undertaken by qualified personnel. The machine must be disconnected from any power source before and during cleaning.

MANUAL TRANSPORT

- When transporting the machine manually, be observant about ramps and/or edges.
- Follow local traffic regulations for the work site to prevent accidents.
- Failure to comply with these regulations may cause injuries or damages.

TRANSPORTING INSIDE VEHICLES

- Secure the machine according to local transport safety regulations before transporting the machine inside a vehicle.
- Be sure to secure any other equipment or materials which are being transported in the same area as the machine to avoid damage to the machine and surrounding areas.

OPERATING PRECAUTIONS

- Any machine, if it is not used according to the recommendations of Warrior Equipment and all legal regulations, may be hazardous for operating and service personnel. The operating authority is responsible for compliance with the safety regulations during operation and maintenance, and for the use of safety devices supplied with the machine, as well as the provision of any needed additional safety devices.
- Never operate the machine when it's not in its upright position. Never operate the machine without proper tools.
Eye and ear protection must be worn at all times.
- Read "Safety Regulations" before operating the machine.

OPERATING INSTRUCTIONS

- See "Precautions" and read the entire user guide before starting the machine.
- Attach the static reduction hose to vacuum, then attach the other end to the desired Warrior Grinding Machine
- Ensure Proper Power and Voltage before attaching the power cord to the machine.
- To operate Manually, turn the Manual/ Remote Switch to left, the Power Indicator Light should light up
- To operate Remotely, turn the Manual/Remote Switch to the right, the Power Indicator Light should light up
(*the green key must be inserted into the remote*)
- The Working Light should light up, indicating that the vacuum works
- Turn air compressor on by pushing the ON/OFF button

PULSE CONTROLLER

When the WEV-670 operates normally, hold down the Set/PRA button for 1 second. The screen will show the first setting time, set up as 40-60, which is the single pulse dust clean time. Time settings can be set by pressing the ^ button. Pulse settings can be set by pressing the SET/PRA button.

NOTE: Failure to keep the single pulse dust clean time over 40 seconds, will cause the air compressor to start more frequently and shorten the lifetime of the air compressor.

AIR COMPRESSOR

If the air compressor is not on or is placed on the wrong settings, the pulsing of the filters will not work properly. Air compressor speeds can be set by pressing the High Speed/ Silence Mode. Speed should be set to 99% high speed mode. Use the pressure buttons, located on the left, indicated by up and down arrows, to set the speed at 0.7-0.8 MPa.

Note: The pressure setting of the screen can not be over 0.8 MPa.

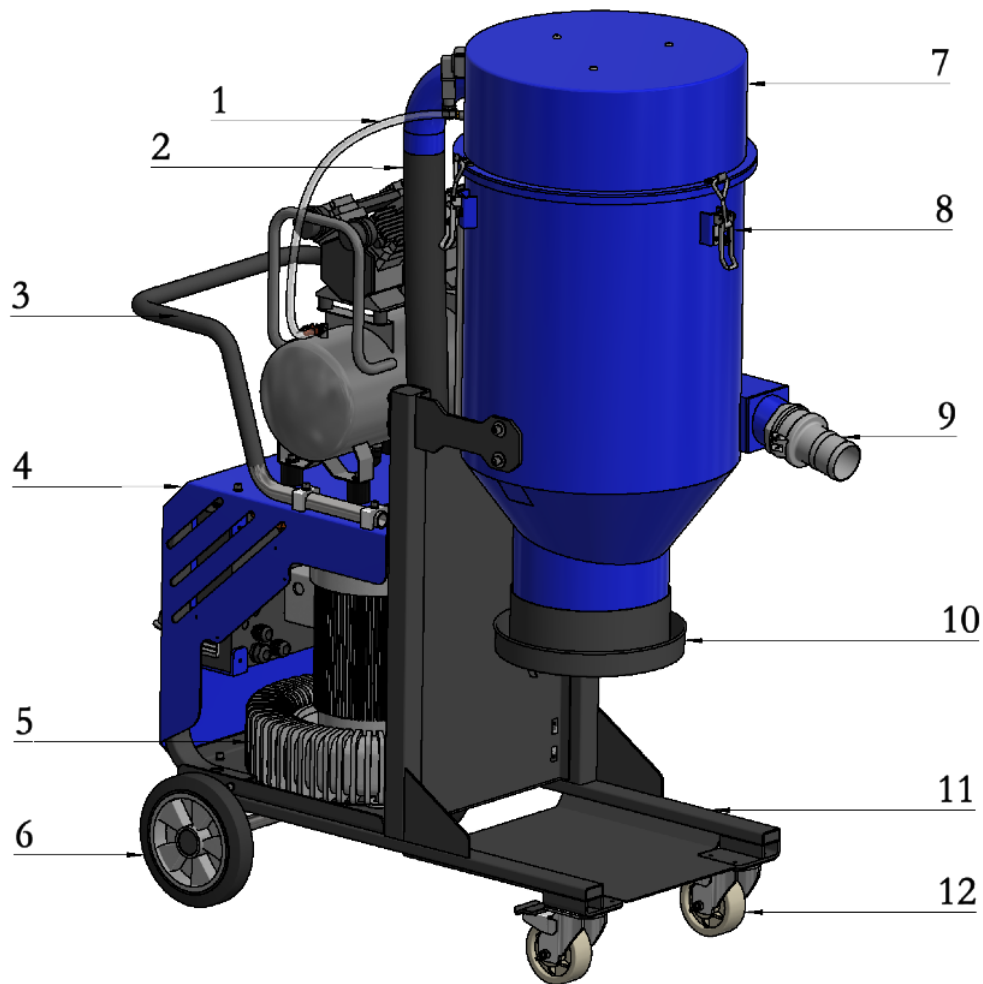
WEV-670 VAC BREAKOUT

NO.	NAME	QTY	NO.	NAME	QTY
NO 1	pressure pipe	1	NO 7	dust barrel cover	1
NO 2	dust suction pipe	1	NO 8	clasp	3
NO 3	handle	1	NO 9	cam lock 3'	1
NO 4	turbine cover	1	NO 10	dust bag fixer	1
NO 5	turbine	1	NO 11	main frame	1
NO 6	wheel	2	NO 12	universal wheel	2

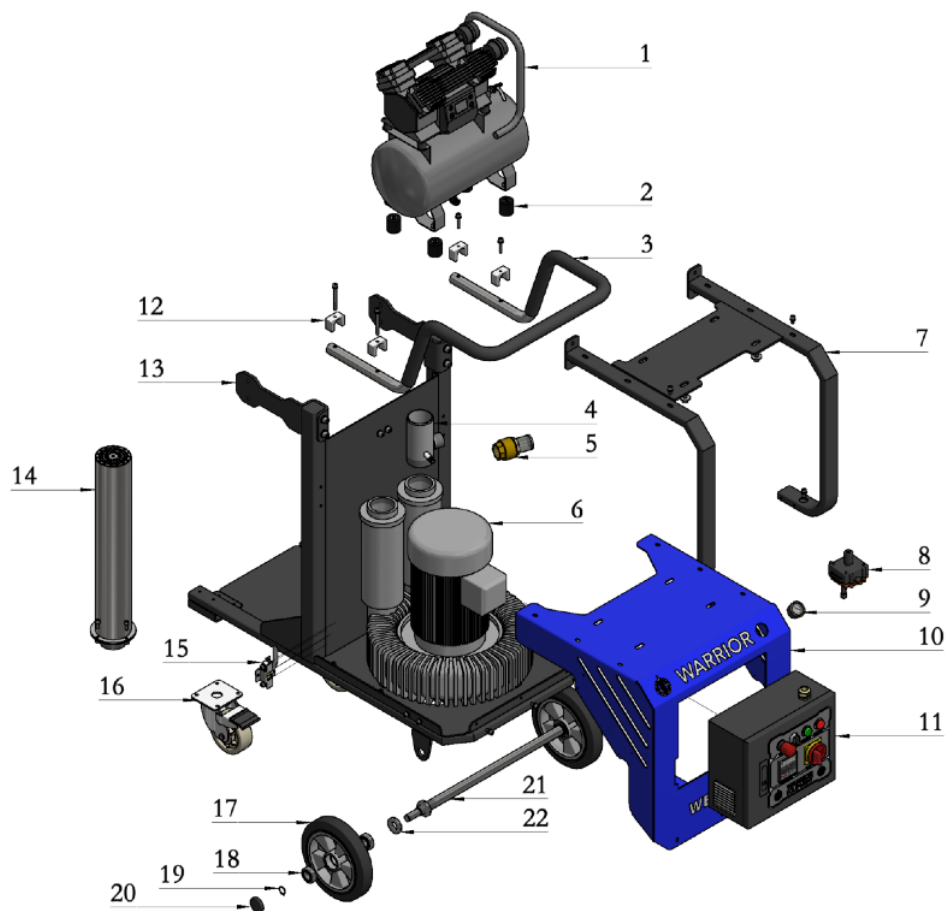
WEV-670 BREAKOUT

NO.	NAME	QTY	NO.	NAME	QTY
NO 1	air compressor	1	NO 11	high voltage box	1
NO 2	rubber	4	NO 12	handle plate	4
NO 3	handle	1	NO 13	dust barrel fixer	2
NO 4	pipe connector	1	NO 14	silencer	1
NO 5	pressure release valve	1	NO 15	drain valve	1
NO 6	turbine	1	NO 16	universal wheel	2
NO 7	air compressor base	1	NO 17	wheel	2
NO 8	remote receiver	1	NO 18	bearing	4
NO 9	negative pressure meter	1	NO 19	axis lock	2
NO 10	turbine cover	1	NO 20	sealed cap	2

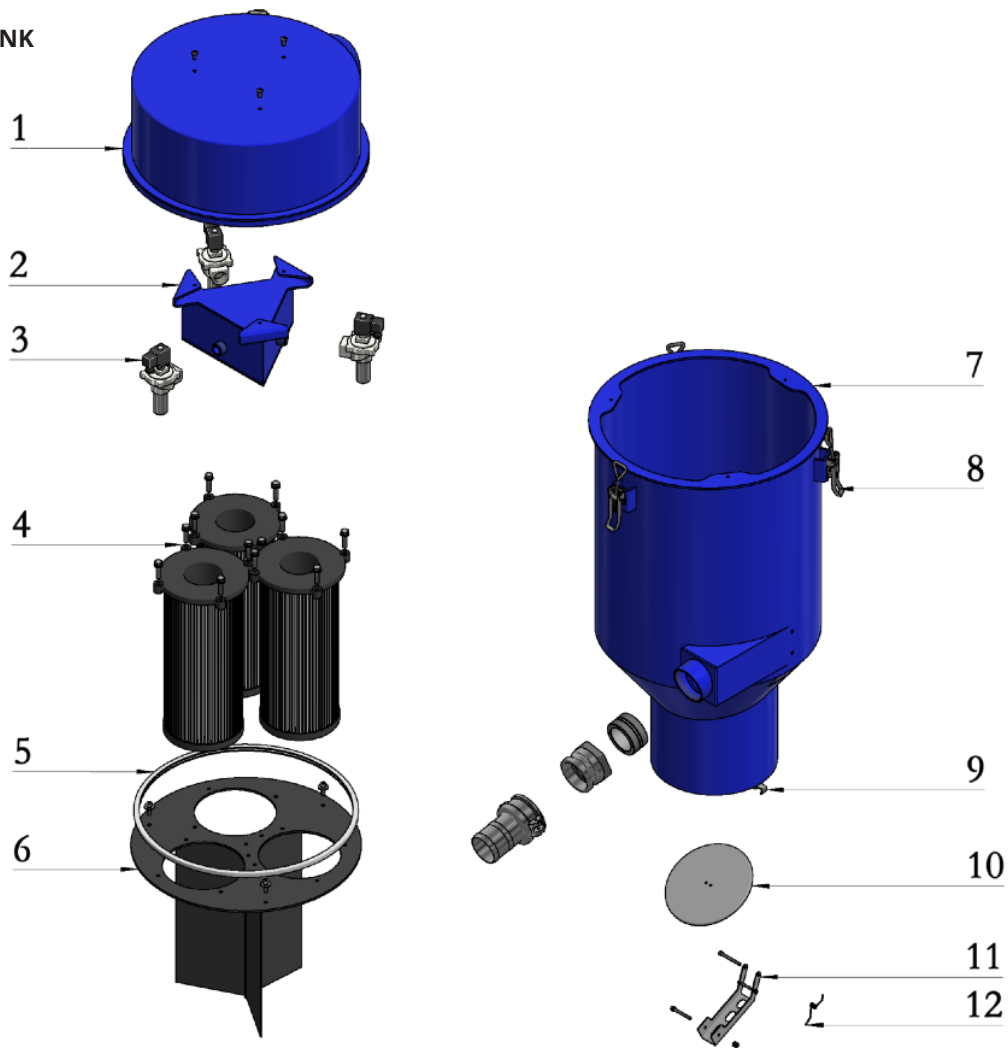
WEV-670 DUST TANK

NO.	NAME	QTY	NO.	NAME	QTY
NO 1	dust barrel cover	1	NO 7	dust barrel	1
NO 2	air storage tank	1	NO 8	clasp	3
NO 3	electrical magnetic valve	3	NO 9	pothead	2
NO 4	filter	3	NO 10	dust board	1
NO 5	sealing strip	1	NO 11	dust board fixer	1
NO 6	filter plate	1	NO 12	torsional spring	1

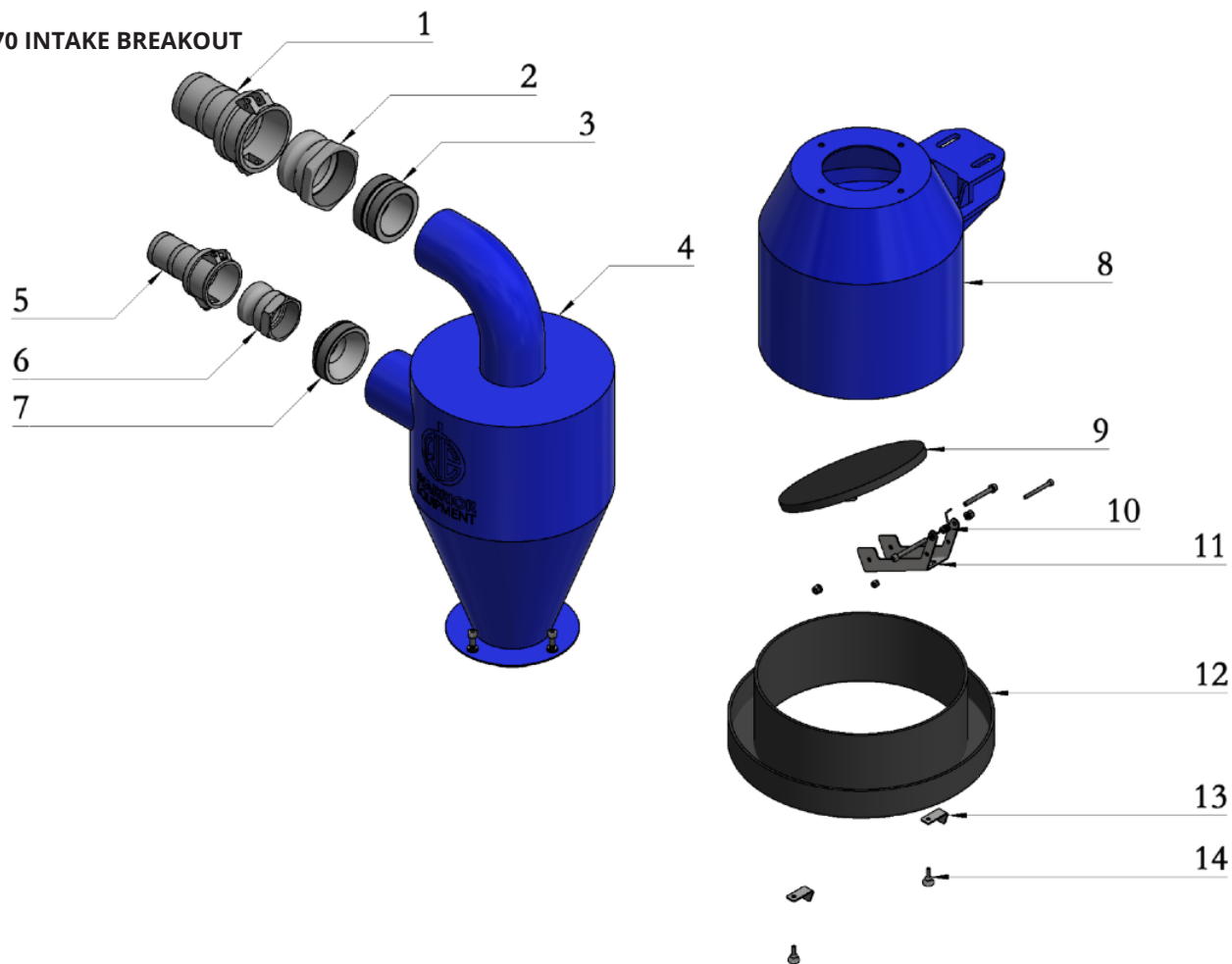
WEV-670 INTAKE BREAKOUT

NO.	NAME	QTY	NO.	NAME	QTY
NO 1	cam lock 3' A	1	NO 8	separator base	1
NO 2	cam lock 3' B	1	NO 9	dust board	1
NO 3	cam lock 3' adapter	1	NO 10	torsional spring	1
NO 4	separator	1	NO 11	dust board fixer	1
NO 5	cam lock 2' A	1	NO 12	dust bag fixer	1
NO 6	cam lock 2' B	1	NO 13	pothook	2
NO 7	cam lock 2' adapter	1	NO 14	screw	2

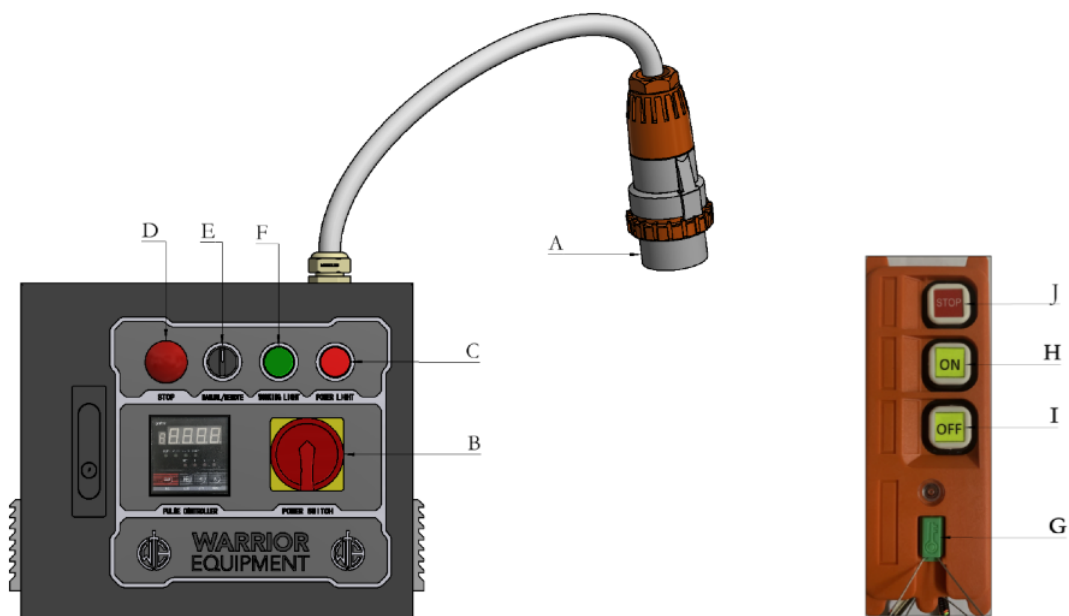
WEV-670 POWER BREAKOUT

NO.	NAME	NO.	NAME
A	plug	F	work indicator light
B	power switch	G	key
C	power indicator light	H	on button
D	stop button	I	off button
E	manual / remote mode	J	stop button

WEV-670 DUST VAC CLEAN TIME



NO.	NAME	NO.	NAME
O	start	Q	shifting
P	setting	R	modify

WEV-670 COMPRESSOR

parameter	
power	2 HP
nominal pressure	1.2mpa
nominal volume flow rate	0.25 m ³ /min
nominal voltage	3 Phase 220V
revolving speed	353 cfm
weight	44 lbs

WEV-670 COMPRESSOR PRESSURE



99%=high speed



50%=silence

WEV-670 WIRING SCHEME

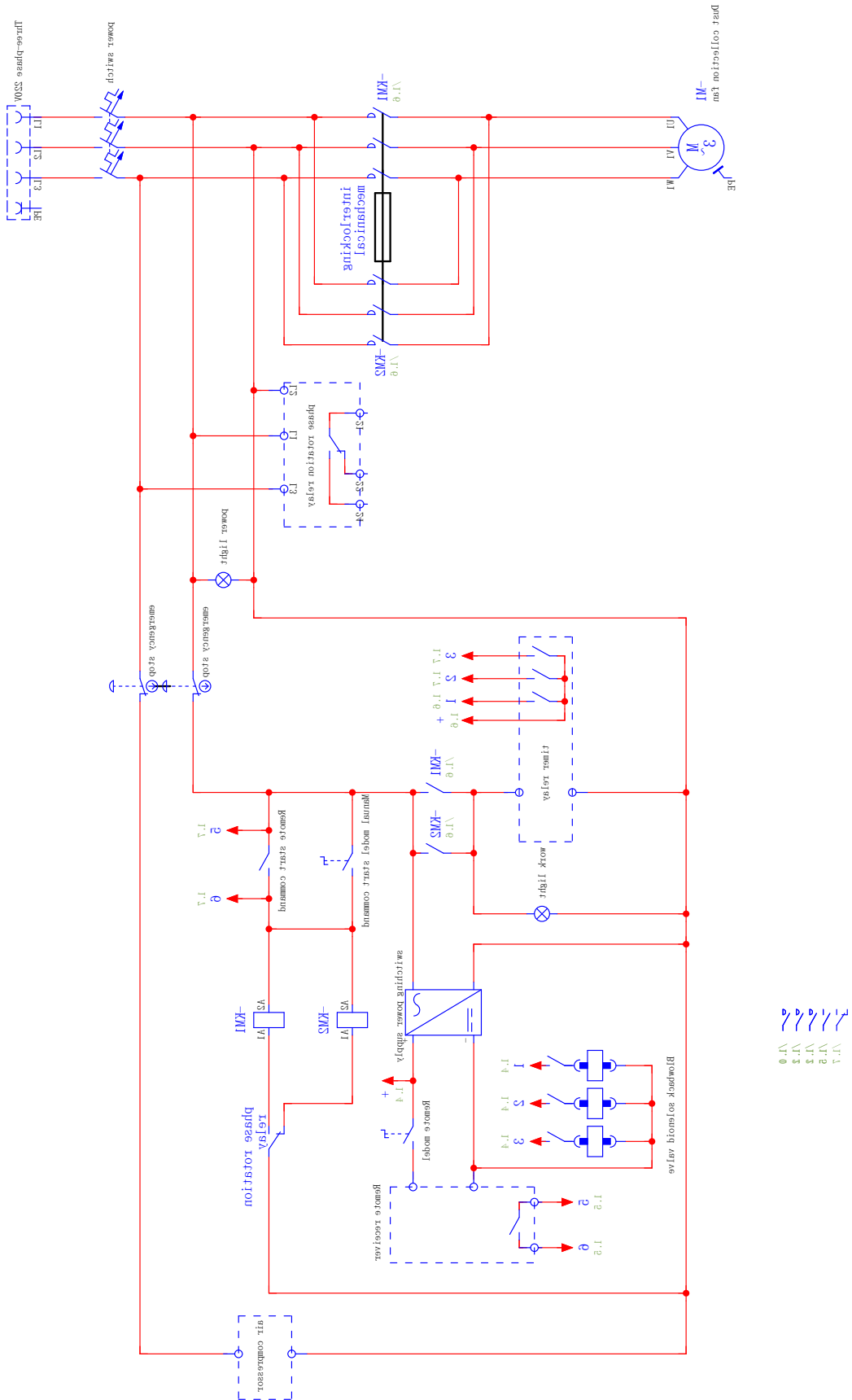

WARRANTY

WHAT THE WARRANTY COVERS AND FOR WHAT PERIOD THE COVERAGE EXTENDS

Warrior Equipment warrants to the original purchaser of this product, who purchased their vacuum from a Warrior Equipment authorized distributor or dealer:

- a. That this product is free of defects in material and workmanship.
- b. That this product, if found to be defective within the stated warranty period, will be repaired free of charge to the consumer (both parts and labor) by an authorized Warrior Equipment service agent.
- c. The warranty period for Warrior vacuums, and all accessories, excluding vacuum cleaner motors, power head motors, and vacuum cleaner casings (body), is one (1) year from the date of purchase.

WHAT IS NOT COVERED BY THIS WARRANTY

This warranty does not cover damage or defects caused by or resulting from repairs, service or alterations to the product or any of its parts or accessories which have been performed by service centers or repairmen not authorized by Warrior Equipment, or damage or defects caused by negligence, accident, abuse, misuse, improper or abnormal usage or maintenance of the product, its parts or accessories. Ordinary wear and tear or cosmetic damage (scuffs, scratches, gauges, dents, etc.) shall not be considered a defect in materials or workmanship.

EXCLUSION OF OTHER WARRANTIES

Except for the limited warranty provided herein, Warrior Equipment disclaims any and all other express warranties with respect to the product. Any warranty of merchantability or fitness for a particular purpose is limited in its duration to the term of the limited warranty provided herein. Some states do not allow limitations on how long an implied warranty lasts, so the above limitation may not apply to you.

LIMITATION OF LIABILITY FOR SPECIAL, INCIDENTAL OR CONSEQUENTIAL DAMAGES

Warrior Equipment will assume no liability, or other obligation with respect to any personal injury or property damage resulting from the use of a vacuum cleaner, or its accessories, replacement parts, etc., which has not been purchased from, or serviced by an authorized Warrior Equipment Dealer. Any purchaser who obtains a vacuum cleaner, accessories, replacement parts, etc., from someone other than an authorized Warrior Equipment dealer proceeds at their own risk. Warrior Equipment specifically disclaims any and all liability, whether directly or by way of indemnity, for special incidental, consequential or other damages, whether based on breach of contract, tort, strict or product liability, or any other legal theory. Some states do not allow the exclusion or limitation of incidental or consequential damages, so the above limitation may not apply to you.

SPECIAL STATE LAWS

This Limited Warranty gives you specific legal rights; you may have other rights, which vary, from state to state.

CONTACT US

Warrior Equipment, a division of Incredible Products, LLC • 1601 McKinley Rd., St. Marys, Ohio 45885 • Office Contact # 1-877-743-9732