



CRUSADER 2204

WE-2204
OWNER'S MANUAL

TABLE OF CONTENTS

1.	Specifications and Models.....	1
1.1	Electrical Specifications	1
1.2	Mechanical Specifications	1
1.3	Tools	1
1.4	Approved Application/ Usage	1
1.5	Included Parts	1
1.6	Overview	2
2.	Safety Precautions	2
2.1	Preventive Safety Measures	2-3
2.2	Personnel Selection and Qualification	4
2.3	Safety: Operation of Machine	4-5
2.4	Electrical safety	5
2.5	Cables	5
2.6	Using a Generator	5
2.7	Definition of "Safety Off Position"	5
2.8	Safety Regarding Maintenance.....	5
2.9	Safety Regarding Transport	5
2.9.1	Manual Transport.....	5
2.9.2	Lifting	5
2.9.3	Inside Vehicles	6
3.	Transport.....	6
3.1	Precautions	6
3.2	Manual Transport.....	6
3.3	Lifting	6
3.4	Inside Vehicles	6
4.	Operation	6
4.1	Precautions	6
4.2	Operation of Machine.....	6
4.3	Water Connection	6
4.4	Control Panel	6
4.5	Start Up.....	7
4.6	Stopping the Machine.....	7
4.7	Adjusting Grinding Speed.....	7
4.8	Changing Grinding Direction	7
4.9	Safety Off Position.....	7
4.10	Grinding.....	7
4.11	Changing Tools	7
4.12	Using the Generator	7
5.	Maintenance	7
5.1	Precautions	7-8
5.2	Daily Inspection Prior to Operation	8
5.3	Maintenance and Inspection List	8
5.4	Cleaning the Machine	8
5.5	Common Faults & Troubleshooting.....	8-12
6.	Machine Breakouts	13-18
7.	Schematic	19
8.	Warranty.....	20
9.	Contact Us.....	20

PERSONAL PROTECTION

It's always recommended to wear the appropriate Personal Protective Equipment (PPE) for the task at hand and follow your employer's safety policy. Commonly known PPE such as safety glasses, gloves, earplugs, respirators, ect . . . are recommended as needed. For further information on OSHA requirements, visit <https://www.osha.gov/Publications/osha3151.pdf>

1. SPECIFICATIONS AND MODELS

WE-2204: Single Phase 220V 5.5HP/ 4KW Motor

1.1 ELECTRICAL SPECIFICATIONS

Never connect the WE-2204 to any other voltage or number of phases than described in this specification. Failure to comply with the correct power may cause machine failure, fire or injuries.

1.2 MECHANICAL SPECIFICATIONS WE-2204



CRUSADER 2204 / WE-2204

WORKING AREA	22.28"	HORSEPOWER	5.5 HP
MACHINE WEIGHT	530 #	HEAD PRESSURE	180-295 #
VOLTAGE	220V	INVERTER	5.5 KW
PHASE	SINGLE	RPM/ROTATION	0-700

1.3 TOOLING

The WE-2204 machine must be equipped with tools approved by Warrior Equipment before operation. See "Training Guide" for information about available tools. Warrior Equipment machines are designed to operate with specific tooling. Warrior Equipment has not tested and cannot warrant machine results and performance with non-approved tooling.

1.4 APPROVED APPLICATION/ USAGE

WE-2204 is designed to operate with horizontal concrete surfaces for concrete surface preparation, coating removal, carpet and tile glue removal, concrete polishing, epoxy removal, terrazzo polishing, and flattening concrete undulations. WE-2204 must not be used for other purposes than stated in this user guide. The manufacturer will not be liable for damage or injury resulting from incorrect usage of WE-2204. Failure to follow the directions in this guide will void the warranty.

1.5 INCLUDED PARTS

The following parts are included with the standard WE-2204 grinding machine:

1. Key to Electrical Cabinet
2. User Guide
3. 75' of Single or 3 Phase Power Cable
4. Plug: Cord to Machine
5. Cam-Lock Vacuum Adapter
6. Cable Holder

1.6 OVERVIEW

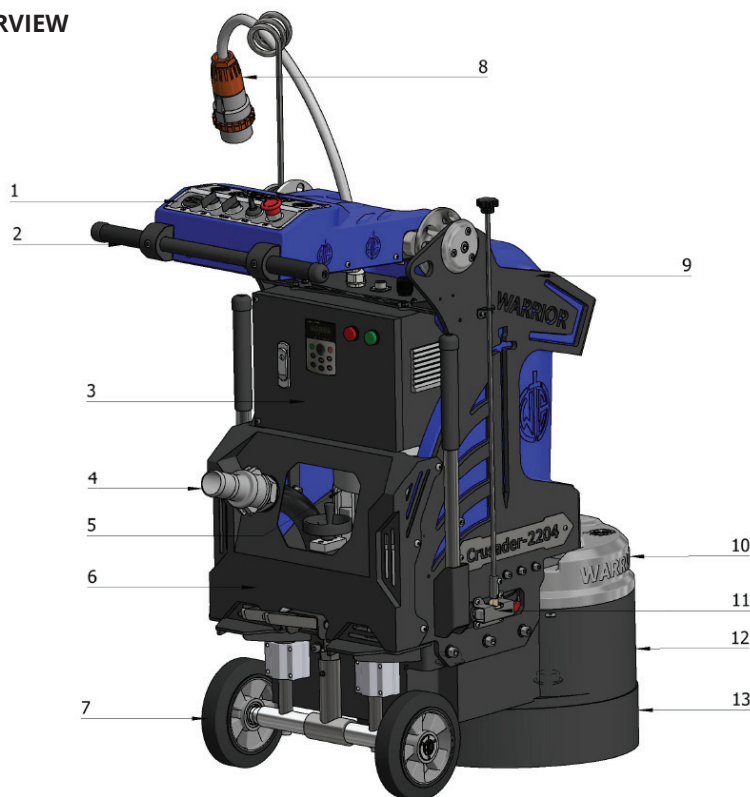

NO	DESCRIPTION	REFERENCE
NO 1	Control Panel	
NO 2	Handle	
NO 3	Electrical Cabinet	
NO 4	Dust Collector Connection	
NO 5	Motor	
NO 6	Motor Cover Plate	
NO 7	Wheel	
NO 8	Power Inlet	
NO 9	Frame	
NO 10	Dust Cover	
NO 11	Water Valve	
NO 12	Grinding Plate	
NO 13	Dust Free Cover	

2. SAFETY PRECAUTIONS

- All Warrior Equipment machines, if not used according to the regulations, may be hazardous for operating, for bystanders, any property, and the operator.
- The operating authority is responsible for compliance with the safety regulations during operation, maintenance, and for the use of all safety devices supplied with the machine, as well as the provision of any additional safety devices.
- Eye and hearing protection must be worn at all times.
- Never operate the machine when it's not in its upright position.
- Make sure there is no debris in the work area. Check the work area for screws or other hard objects in the concrete.
- Don't use the machine if there are any foreign objects stuck into the surface. Such objects must be removed prior to operation of machine.

2.1 PREVENTIVE SAFETY MEASURES

- Keep the user guide near the location where the machine is being operated and must be within reach at all times.
- General and legal regulations regarding accident prevention and environmental protection must be complied with as per local regulations. For example, the handling of hazardous substances, or to the provision and wearing of personal protection equipment, as well as compliance with traffic regulations.
- The user guide is not the only safety instructions that are to be followed. It must be supplemented by other instructions, including the duty to supervise and report incidents relating to particular working practices, work organization, work procedures, and personnel safety.
- Personnel entrusted with working with the machine must read the User Guide before starting work, in particular the "Safety Regulations" chapter. To read these instructions after work is started is too late. This applies to incidental activities such as setting up of the equipment, carrying out maintenance work, or training staff to work with the machine.
- From time to time the working practices of the operators are advised be checked by a supervisor especially to the items regarding awareness of safety and hazards.
- Operators must tie back long hair, and not wear loose clothing or jewelry including rings. There is a risk of injury through items getting caught, or being drawn into moving machinery.
- Eye and hearing protection must be worn at all times.
- Use personnel protection equipment that is necessary or required by local regulations. Take notice of all safety and hazard notices of the machine.

- All safety and hazard notices at or on the machine must be kept complete and legible.
- If safety-critical changes occur to the machine or its working method, the machine must be shut down immediately. The cause of the fault must be established and deemed safe to use by supervisor.
- Changes, add-ons or conversion to the machine, which might impair safety, must not be made, without the permission of Warrior Equipment and can cause serious injury or void the warranty.
- Repair parts must comply with the technical requirements specified by the Warrior Equipment.
- Recurring checks and inspections specified in this User Guide must be complied with to maintain warranty. A proper maintenance log should be updated with any and all checks, maintenance, and repairs. Present this log when taking your machine to a Warrior Equipment service center to maintain warranty.
- To perform maintenance work correctly technician must be equipped with the proper tools and training for the task.
- Repairs may only be made by Warrior Equipment certified service technicians.
- Operation of this machinery may generate sparks under certain circumstances. Personnel working with the machine must be aware of the risk of fire and how to handle a fire situation properly.
- Do not use the machines in areas with highly flammable and/or explosive materials.

2.2 PERSONNEL SELECTION AND QUALIFICATION

- Any work or modifications on the machine may only be undertaken by trained personnel.
- Specify clearly the responsibilities of personnel for operation, setting up, servicing and maintenance work.
- Only trained and authorized personnel may operate or work on the machine.
- Define responsibilities of the machine operator, with regard to traffic safety regulations, and inform him/her, not to take instructions from third parties who may not be complying with the local safety requirements.
- Personnel, who are being trained to operate equipment, may only use the machine under constant supervision of an experienced person authorized for training.
- Work on electrical equipment may only be undertaken by a skilled electrician or by trained persons under the supervision of a skilled electrician in accordance with the local electrical engineering regulations.

2.3 SAFETY: OPERATION OF MACHINE

- Never permit any method of working that impairs safety.
- Recognized official procedures have to be used to ensure the machine is only operated in safe and best conditions.
- Only operate the machine when all safety devices and related safety equipment are present and operational.
- Check the machine visually for any damage and defects at least once a day and prior to each use.
- In the event of operational malfunctions the machine must be shut down immediately and secured. Secure the work area around the machine in public areas providing a safe distance of at least 10'x10' area around the machine.
- Faults must be immediately rectified before continued operation of the machine.
- Carry out the switch on, and switch off operations in accordance with this user guide.
- Before switching on the machine make sure that no-one can be endangered when the machine starts up.
- Never operate the machine when not in its upright position.
- Do not switch off or remove the exhaust and or the ventilation devices while the machine is running.
- All persons in the proximity of the machine must wear hearing and eye protection as well as safety shoes.
- Machine operator must wear close-fitting protective clothing.
- Only use power cables that are sized and marked in accordance with the overall power consumption of the machine and the valid VDE and OSHA guidelines.
- Make sure there is no debris in the work area. The machine could throw loose debris causing injury and property damage.
- Check the work area for screws or other hard objects in the concrete. Don't use the machine if there are any foreign objects stuck into the surface. Such objects must be removed prior to operation of machine

2.4 ELECTRICAL SAFETY

- The power source must be equipped with proper breakers and/or fuses. All cables used must be marked and rated according to the local legal laws. Consult with OSHA or other regulatory agencies requirements before operation .
- Never connect the machine to a power source that does not provide a protective ground.
- Work on electrical equipment may only be undertaken by a skilled electrician or by trained persons under the supervision of a skilled electrician as well as in accordance with the local electrical engineering regulations.
- Use only extension cables for extending the main cable, that are sized and marked in accordance with the overall power consumption of the machine and the valid VDE and OSHA guidelines.
- The electrical equipment to be used must be inspected regularly. Defects such as loose connections or scorched cables must be rectified immediately before use of equipment. Call a skilled electrician or our customer services if you have any uncertainties.

- A second person must be in attendance whilst the electrical engineer is working on the equipment. The work area must be secured against any third party entering the work area. Follow local electrical engineering regulations while working on the machine. Never leave a machine unattended. Only tools that are insulated against electricity should be used by a certified technician when performing any work involved with electricity.
- Only allow work after you are familiar with the electrical engineering regulations that apply to the local area.
- Only use voltage meters that comply with the regulations when troubleshooting. From time to time have voltage meters inspected and tested to ensure that they are operationally efficient.

2.5 CABLES

- Only use cables that are marked and rated according to the specifications. Don't use excessive length of the cables.
- If longer cables are needed, consult an electrician before use of a cable rated for more current. Connection to a distribution center near the machine is normal procedure.
- Never lay the cable in a loop when operating the machine, this will cause the cable to heat up and may cause fire.

2.6 USING A GENERATOR

- The generator must be equipped with protective ground and operated in accordance with the current EN-VDE directives (this applies to the protective ground conductor in particular) in order to ensure that all safety devices are functioning and eliminate possible damage to electrical components.

2.7 DEFINITION OF THE "SAFETY OFF POSITION"

The machine is in a safe condition where it cannot be a hazard.

How to set the machine in the Safety off position:

1. Switch off the machine
2. If a dust collector is used, switch it off
3. Wait for all drives to come to a complete stop
4. Disconnect the main power
5. Secure against unintended restart

Always disconnect the main power at the machine end. This will prevent other persons from accidentally reconnecting the main power while working on the machine.

2.8 SAFETY REGARDING MAINTENANCE

- Set the machine into the Safety off position before beginning any work on the machine.
- Never work on the machine while power is still connected. Ensure all parts have come to a complete stop before performing any work.
- When the machine is positioned on its back it may tilt up into the upward position. Take extra care to prevent this from happening to ensure that no injuries or damages occur.
- When the machine has been operated the tooling, plates, and other parts on the gear box may be hot. Take extra care to prevent burn injuries.
- Any adjustment, servicing and inspection work, specified in this User Guide or elsewhere or any information on the replacement of parts and equipment must be undertaken and/or complied with.
- These activities may only be undertaken by qualified personnel.
- The machine must be disconnected from any power source before and during cleaning.

2.9 SAFETY REGARDING TRANSPORT

- Always remove the tools before transport. The tools may fall off or damage the surface the machine is being transported in.

2.9.1 MANUAL TRANSPORT

- When transporting the machine manually be observant about ramps and/or edges. Follow local traffic regulations for the work site to prevent accidents.
- Failure to comply with these regulations may cause injuries or damages.

2.9.2 LIFTING

- The machine must be secured according to local safety regulations before lifted.
- No person is ever to be allowed under a lifted machine.
- The machine must be lifted according to the instructions in "Lifting"
- Observe the machine's point of balance before lifting and determine if it is safe to proceed with lifting the machine.
- Failure to comply with these instructions may cause injuries or damages.
- Only use straps approved for no less than 25% more than the machine weight and height requirements.

2.9.3 INSIDE VEHICLES

- Secure the machine according to local transport safety regulations before transporting the machine inside a vehicle.
- Be sure to secure any other equipment or materials that are being transported in the same area as the machine to avoid damage to the machine and surrounding areas.

3. TRANSPORT PRECAUTIONS

3.1 PRECAUTIONS

- Read entire manual before attempting to transport the machine.

3.2 MANUAL TRANSPORT

- After detaching the tools according to the instructions, adjust the weights back into the locked position. Raise the handle and lock into place to create the needed leverage. Then push the handle downwards, while stepping on the pedal bracket to lift the gear box. Push the machine in desired direction. Always have a second person help to avoid injuries when loading on a trailer ramp. The use of a properly installed winch is recommended.

3.3 LIFTING

- Before attempting to lift the machine, read “Lifting” instructions.
- Detach the tools according to the instructions.
- Fasten the straps used for lifting at two or more of the four lifting points on the frame.
- Ensure proper balance of the machine, be sure that the straps are securely fastened, and the area is all clear of any persons, before lifting of the machine.

4. OPERATION PRECAUTIONS

- Any machine, if it is not used according the recommendations of Warrior Equipment and all legal regulations, may be hazardous for operating and service personnel. The operating authority is responsible for compliance with the safety regulations during operation and maintenance, and for the use of safety devices supplied with the machine, as well as the provision of any needed additional safety devices.
- Never operate the machine when its not in its upright position. Never operate the machine without proper tools. Eye and ear protection must be worn at all times. Make sure there is no debris in the work area.
- Check the work area for screws or other hard objects in the concrete. Don't use the machine if there are any foreign objects stuck into the surface. Such objects must be removed prior to operation of machine.
- Read “Safety Regulations” before operating the machine.

4.2 OPERATION OF MACHINE

- The gear box has four grinding heads. Two that rotate in the opposite direction of the other two. Each grinding head is equipped with a 3 pin tool holder secured with magnets.
- Use caution when installing tools to keep any part of the operator's hands or body from being pinched or injured.
- Ensure each magnet is free of debris or anything that would hinder the tooling from sitting flush on the tool holding pins and magnets.

4.3 WATER CONNECTION

- Closed: No water will flow
- Open: Water will flow

4.4 CONTROL PANEL



- 1 USB INTERFACE
- 2 LED LIGHT SWITCH
- 3 FWD/REV SWITCH
- 4 SPEED SWITCH
- 5 EMERGENCY STOP

4.5 STARTUP

- See "Precautions" and read entire user guide before starting the machine.
- How To Start The Machine.
- Ensure Proper Power and Voltage before attaching the power cable to the machine.
- Make sure that the power plug and hoses for dust collector and water (if used) are connected to the machine.
- Turn on the dust collector (if one is in use) before the machine.
- Push the handle downwards to lift excess pressure and weight off the tooling. The gear box and tooling should not be lifted up from touching the ground. The goal is to only reduce pressure and weight upon start up.
- Ensure that the "EMERGENCY STOP" button is in its upper position. If not, release it by turning it clockwise until it rises.

Press the "STOP" button in to reset.

- Turn the FWD/REV Switch clockwise or counter clockwise to start the operation of the machine.
- Adjust the speed control according to the tools used. (The lower the grit size of the tooling the slower the speed.)

4.6 STOPPING THE MACHINE

- How to stop the machine.
- Press the "STOP" button for urgent stopping.
- Turn the FWD/REV Switch clockwise or counter clockwise to stop the operation of the machine.
- Wait for the machine to come to a complete stop before letting go of the handles.
- Turn off the dust collector if used.

4.7 ADJUSTING GRINDING SPEED

- Turn the "SPEED" knob to increase or lower the grinding speed.

4.8 CHANGE GRINDING DIRECTION

- Use the FWD/REV switch to select grinding direction. The machine will automatically come to a complete stop and restart in the selected direction.

4.9 SAFETY OFF POSITION

- When working on the machine, either maintenance or tool change, the machine must be set to the "Safety off position". See the definition of the "Safety off position" for further information.

4.10 GRINDING

- Refer to "training guide" for instructions and information about grinding processes.

4.11 CHANGING TOOLS

Before changing tools, read Safety instructions and recommendations regarding maintenance.

1. Insert the segment onto the pins, the 3 holes lining up with the 3 pins.
2. Watch your fingers to avoid injury.
3. The segment is now fit on the Crusader WE-2204 plates.
4. In reverse use a screw driver or small prying tool to loosen/pry the segments off for removal or tool change.

4.12 USING WITH GENERATOR(S)

The generator must be equipped with protective ground and operated in accordance with the current OSHA and EN-VDE directives (this applies to the protective ground conductor.) Ensure that all safety devices are functioning and eliminate possible damage to electrical components. Ensure correct voltage and phase is selected on the generator before plugging in the machine.

5. MAINTENANCE

5.1 PRECAUTIONS

- Set the machine into the Safety off position before beginning any work on the machine.
- See Definition of the "Safety off position".
- Read "Electrical safety" before beginning any maintenance work.
- Never work on the machine while power is still connected!
- All parts must have come to a complete stop before beginning any work.
- When the machine is lying down on its back it might tilt to its upwards position. Take extra care to prevent this from happening to ensure that no injuries or damages occur.
- When the machine has been operating the segments, plates and other parts on the gear box may be hot. Take extra care to prevent burn injuries.
- Adjustment, servicing and inspection work on the period of time limits, specified in this User Guide as well as any information on the

- Adjustment, servicing and inspection work on the period of time limits, specified in this User Guide as well as any information on the replacement or parts and equipment must be undertaken and/or complied with.
- These activities may only be undertaken by qualified personnel.
- The machine must not be connected to any power source while cleaning.

5.2 DAILY INSPECTION PRIOR TO OPERATION

Inspect the following items prior to operation:

- Inspect the wheels for damage.
- Inspect the grinding heads. Dirt between the Warrior Equipment plate(s) and the grinding hub can impair the flexibility of the grinding head.
- Inspect the wiring and cables for damage or loose connections.
- If any screws appear loose, tighten them.
- Look over the machine for any other damage.

5.3 MAINTENANCE AND INSPECTION LIST

- Always clean the machine after every use.
- If wet grinding you must remove all slurry from machine to avoid premature wear of rubber parts.
- Every 600 hours change the gearbox oil. Contact Warrior Equipment for more information and procedure instructions.

5.4 CLEANING THE MACHINE

- Before starting to clean the machine, make sure it is in its "Safety off position" The power must not be connected while cleaning the machine.
- Do not use highly pressurized water to clean the machine. Low pressure and a brush with water and soap is recommended.

5.5 COMMON FAULTS & TROUBLESHOOTING

The 7200MA have the protective and warning self-diagnostic functions. If fault occurs, the fault code is displayed on the digital operator. The fault contact output (RA-RB-RC or R1A-R1B-R1C, DO1, DO2 or R2A-R2C) operates, and the inverter shuts off to stop the motor. If warning occurs, the digital operator will display the warning code. However, the fault-contact output does not operate, (except some certain cases, see page on "Warning" and Self-Diagnosis Functions"). The digital operator will return to its previous status when the above warning is clear.

- When a fault has occurred, refer to the following table to identify and to clear the cause of fault.
- Use one of the following methods to reset the fault after restarting the inverter.

1. Stop the inverter.
2. Switch the fault reset input at terminal ④ signal or press the RESET key on the digital operator.
3. Turn off the main circuit power supply and turn on again.

SEE NEXT FEW PAGES FOR COMMON FAULT ERRORS AND ACTION TO BE TAKEN

5.5 COMMON FAULTS & TROUBLESHOOTING

ERRORS	ACTION TO BE TAKEN
<ul style="list-style-type: none"> • Power capacity is too small • Voltage drop due to wiring resistance • Large capacity motor connected to the same power system has been started • Defective electromagnetic contractor 	<ul style="list-style-type: none"> • Check the source voltage and wiring • Check the power capacity and power system
<ul style="list-style-type: none"> • Extremely rapid accel • Short-circuit or ground-fault at the inverter output side • Motor of a capacity greater than the inverter rating has been started • High-speed motor and pulse motor has been started 	<ul style="list-style-type: none"> • Extend the accel. time • Check the load wiring
<ul style="list-style-type: none"> • Motor dielectric strength is insufficient • Load wiring is not proper 	<ul style="list-style-type: none"> • Check the motor wiring impedance and the load wiring.
<ul style="list-style-type: none"> • Insufficient deceleration time • High input voltage compared to motor rated voltage 	<ul style="list-style-type: none"> • Extend the accel. time • Use a braking resistor
<ul style="list-style-type: none"> • Defective cooling fan • Ambient temperature rise • Clogged filter 	<ul style="list-style-type: none"> • Check for the fan, filter and the ambient temperature
<ul style="list-style-type: none"> • Overload, low speed operation or extended accel. time • Improper V-f characteristic setting 	<ul style="list-style-type: none"> • Measure the temperature rise of the motor. • Decrease the output load • Set proper V/f characteristic
<ul style="list-style-type: none"> • Improper rated current (Cn-09) setting 	<ul style="list-style-type: none"> • Set proper V/f characteristic • Set proper rated current (Cn-09) • If inverter is reset repetitively before fault removed, the inverter may be damaged
<ul style="list-style-type: none"> • Machine errors or overload 	<ul style="list-style-type: none"> • Check the use of the machine • Set a higher production level (Cn-32)
<ul style="list-style-type: none"> • Fault input of external signal ③ ⑤ ⑥ ⑦ and ⑧ 	<ul style="list-style-type: none"> • Identify the fault signal using Un-11
<ul style="list-style-type: none"> • Disturbance of external noise • Excessive impact or vibration 	<ul style="list-style-type: none"> • Reset NVRAM by running Sn-03 • Replace the control board if the fault can't be cleared
<ul style="list-style-type: none"> • Improper setting of ASR parameter or over-speed protective level 	<ul style="list-style-type: none"> • Check the parameters of ASR and the protection level
<ul style="list-style-type: none"> • The PG wiring is not properly connected or open-circuit 	<ul style="list-style-type: none"> • Check the PG wiring
<ul style="list-style-type: none"> • Improper setting of ASR parameter or speed deviation level 	<ul style="list-style-type: none"> • Check parameters of ASR and speed deviation level
<ul style="list-style-type: none"> • External noise • Excessive vibration or impact communication wire • Not properly contacted 	<ul style="list-style-type: none"> • Check the parameter setting, including Sn-01, Sn-02 • Check if the communication wire is properly contacted • Restart, if fault remains, please contact your representative

5.5 COMMON FAULTS & TROUBLESHOOTING

LCD DISPLAY	ERRORS	FAULT CONTACT OUTPUT
(blinking) Alarm DC Volt Low	The main circuit DC voltage becomes lower than the lower under-voltage level before motor starts	No Operation
(blinking) Alarm Over Current	The main circuit DC voltage becomes higher than the lower under-voltage level before the motor starts	No Operation
(blinking) Alarm Ground Fault	The thermal protection contract is input to the external terminal	No Operation
(blinking) Alarm Overheat	Over torque is detected while the output current is larger than the equal to the setting of Cn-26. However, the Sn-12 has been set such that the inverter continues to run and disregard the over-torque warning	No Operation
(blinking) Alarm Over Torque	The temperature of the cooling fan reaches the detection level	No Operation
—	Stall prevention operates while acceleration Stall prevention operates while running Stall prevention operates while deceleration	No Operation
(blinking) Alarm Ext. Fault	Forward and reverse rotation commands are simultaneously detected for a period of time exceeding 500ms. (The inverter is stopped according to the stop method preset by Sn-04)	No Operation
(blinking) Alarm RS-485 Interrupt	MODBUS Communication fault occurs. The inverter remains operating.	No Operation
Comm. Fault	Transmission fault of digital operator	No Operation
(blinking) Alarm BB	External BB signal (terminal ③ is input) The inverter steps and the motors stops without breaking	No Operation
Alarm Input Error	Improper inverter capacity (Sn-01) setting Improper setting of multi-function input signal (Sn-25, 26, 27 and 28) Improper setting of V/F characteristic (Cn-02-08) Improper setting of Cn-18, Ca-19	No Operation
(blinking) Alarm Over Speed	Excessive speed (operation remains)	No Operation
(blinking) Alarm PG Open	PG Open circuit (operation remains)	No Operation
Alarm Sp. Deviat Over	Excessive speed deviation (operation remains)	No Operation
Load Fail	Error during upload and download (operation remains)	No Operation
EEPROM Fault	Operator EEPROM error	No Operation
Upload Error	Data incorrect during communication from the operator to the inverter	No Operation
Download Error	Data incorrect during communication from the operator to the inverter	No Operation
Alarm Auto Turn Error	Motor parameter auto-tuning error	No Operation

5.5 COMMON FAULTS & TROUBLESHOOTING

ERRORS	ACTION TO BE TAKEN
<ul style="list-style-type: none"> • Input voltage drop 	<ul style="list-style-type: none"> • Measure the main circuit DC voltage, if the voltage is lower allowance level, regulate the input voltage
<ul style="list-style-type: none"> • Input voltage rise 	<ul style="list-style-type: none"> • Measure the main circuit DC voltage, if the voltage is higher than allowance level, regulate the input voltage
<ul style="list-style-type: none"> • Overload • Cooling fan fault. Ambient temperature rises • Clogged filter 	<ul style="list-style-type: none"> • Check for the fan, filter and the ambient temperature
<ul style="list-style-type: none"> • Machine error or overload 	<ul style="list-style-type: none"> • Check for the use of the machine
<ul style="list-style-type: none"> • Insufficient Accel/Decel. time • Overload • Excessive load impact occurs while operating 	<ul style="list-style-type: none"> • Set a higher protection level (Cn-32)
<ul style="list-style-type: none"> • Operation sequence error • 3-wire/2-wire selection error 	<ul style="list-style-type: none"> • Increase Accel/Decel time • Check the load
<ul style="list-style-type: none"> • External noise • Excessive vibration or impact on communication wire • Not properly contacted 	<ul style="list-style-type: none"> • Check the circuit of system • Check the setting of system parameters Sn-25, 26, 27, & 28
<ul style="list-style-type: none"> • Comm. between digital operator and inverter has not been established after system starts for 5 seconds • Communication is established after system starts, but transmission fault occurs for 2 seconds 	<ul style="list-style-type: none"> • Check the parameter setting, including Sn-01, Sa-02 • Check if the comm. wire is not properly attached • Restart, if fault remains, please contact us
<ul style="list-style-type: none"> • External BB signal is input 	<ul style="list-style-type: none"> • Re-plug the connector of the digital operators • Replace the control board • After external BB signal is removed, execute the speed search of the inverter
<ul style="list-style-type: none"> • Inverter KVA setting error 	<ul style="list-style-type: none"> • Set proper KVA value. Be aware of the difference of 220V and 440V
<ul style="list-style-type: none"> • The valve of Fa-25-Sa-28 is not in ascending order (Ex: Sa-25=03, Sa28=02, those are improper settings) • Set speed search command of 21 and 22 simultaneously 	<ul style="list-style-type: none"> • Set these values by order (the value of Sn-25 must be smaller than those of Sn-26, 27, 28) • Command 21 and 22 can not be set on two multi-function input contacts simultaneously
<ul style="list-style-type: none"> • The values of Ca-02-Cs-08 do not satisfy $F_{max} > , FA > , FB > , F_{min} >$ 	<ul style="list-style-type: none"> • Change the settings
<ul style="list-style-type: none"> • Upper limit and lower limit setting is incorrect 	<ul style="list-style-type: none"> • Change the settings
<ul style="list-style-type: none"> • Improper ASR parameter setting or over-torque protection level 	<ul style="list-style-type: none"> • Check the ASR parameter and over-torque protection level
<ul style="list-style-type: none"> • The circuit of PG is not properly connected or open-circuit 	<ul style="list-style-type: none"> • Check the wiring of PG
<ul style="list-style-type: none"> • Improper ASR parameter setting or over-torque protection level 	<ul style="list-style-type: none"> • Check the ASR parameter and over-torque protection level
<ul style="list-style-type: none"> • Bad communication during operator and inverter • The connector is not properly connected 	<ul style="list-style-type: none"> • Check if the connector is not properly connected
<ul style="list-style-type: none"> • Operator EEPROM error 	<ul style="list-style-type: none"> • Disable load function of operator • Replace the operator
<ul style="list-style-type: none"> • Incorrect inverter data format • Communication noise 	<ul style="list-style-type: none"> • Download the data to the operator again • Check if the connector is not properly connected
<ul style="list-style-type: none"> • Communication noise 	<ul style="list-style-type: none"> • Check if the connector is not properly connected
<ul style="list-style-type: none"> • Inverter capacity and motor rating are not properly matched • The wiring between inverter and motor is disconnected • Motor load unbalance 	<ul style="list-style-type: none"> • Connect the inverter/motor capacity ratio, wiring cable and motor head

5.5 COMMON FAULTS & TROUBLESHOOTING

LCD DISPLAY	ERRORS	FAULT CONTACT OUTPUT
Fault DC Volt Low	The main circuit DC voltage becomes lower than the low voltage detection level (Cn-34)	Operation
Fault Over Current	The inverter output current becomes approx. 200% and above the inverter rated current	Operation
Fault Ground Fault	A ground fault occurs at the inverter output side and the ground-fault current exceeds approx. 50% of the inverter rated current	Operation
Fault Over Voltage	The main circuit DC voltage becomes excessive because of regeneration energy caused by motor decelerating	Operation
Fault Overheat	The temperature of the cooling fan reaches the detection level	Operation
Fault Motor Overload	Motor overload is detected by the electronic thermal relay (motor protection)	Operation
Fault Inverter Overload	The electronic thermal sensor detects inverter overload while the output current exceeds 112% of rated value (inverter protection)	Operation
Fault Over Torque	Over torque is detected while the output current is larger than or equal to the setting of CN-26. (machine prevention)	Operation
Fault Ext. Fault 3	External fault signal ③	Operation
Fault Ext. Fault 5	External fault signal ⑤	Operation
Fault Ext. Fault 6	External fault signal ⑥	Operation
Fault Ext. Fault 7	External fault signal ⑦	Operation
Fault Ext. Fault 8	External fault signal ⑧	Operation
Fault Inverter EEPROM	EEPROM fault EEPROM (BCC, no) is bad	Operation
Fault Inverter A/D	A/D Converter (inside the CPU) fault	Operation
Fault PG over Sp.	Excessive PG speed fault	Operation
Fault PG Open	PG is open-circuit	Operation
Fault Sp Deviat Over	Excessive speed deviation	Operation
Fault RS-485 Interrupt	MODBUS communication fault occurs. The inverter remains operating.	Operation

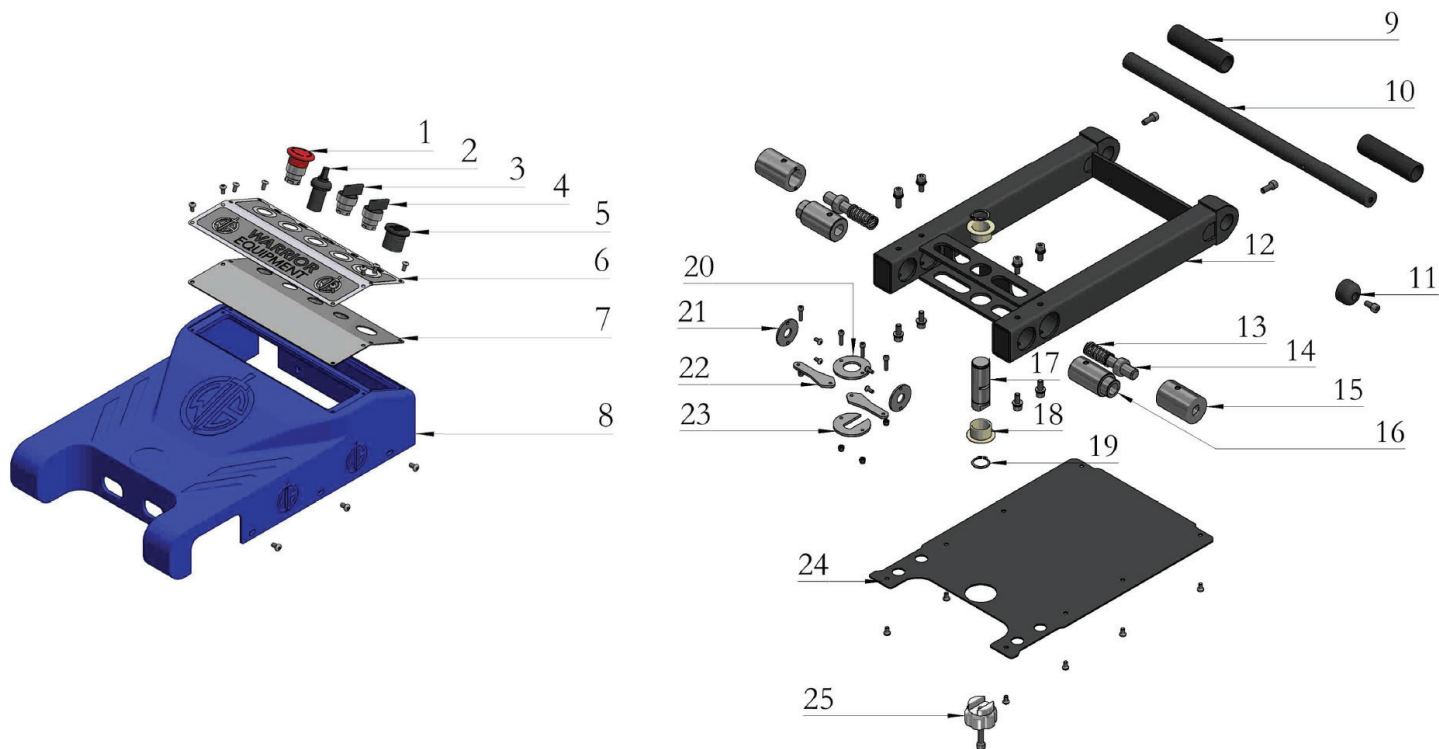
6. MACHINE EXPLOSION PARTS
WE-2204 FRAME EXPLOSION

NO	NAME	QUANTITY
NO 1 (A)	Emergency Stop Button	1
NO 2	Speed Switch	1
NO 3	FWD/REV Switch	1
NO 4	LED Light Switch	1
NO 5	USB Interface	1
NO 6	Control Button Panel	1
NO 7	Control Button Baseboard	1
NO 8 (B)	Handle Cover	1
NO 9	Hand Shank Cover	2
NO 10	Operation Handle	1
NO 11	Handle Plug	2
NO 12	Hand Square Tube	1
NO 13	Pressure Spring	2
NO 14	Fixed Pin	2
NO 15	Fixed Pin Sleeve	2
NO 16	Connector Shaft Cover	2
NO 17	Rotation Shaft	1
NO 18 (C)	Guide Sleeve	2
NO 19 (D)	Hoop $\varnothing 28$	2
NO 20	Connector fixed Gasket-1	1
NO 21	Fixed Pin Cover Gasket	2
NO 22	Connector	2
NO 23	Connector fixed Gasket-2	1
NO 24	Handle Cover Base Board	1
NO 25	Rotate Wrench	1

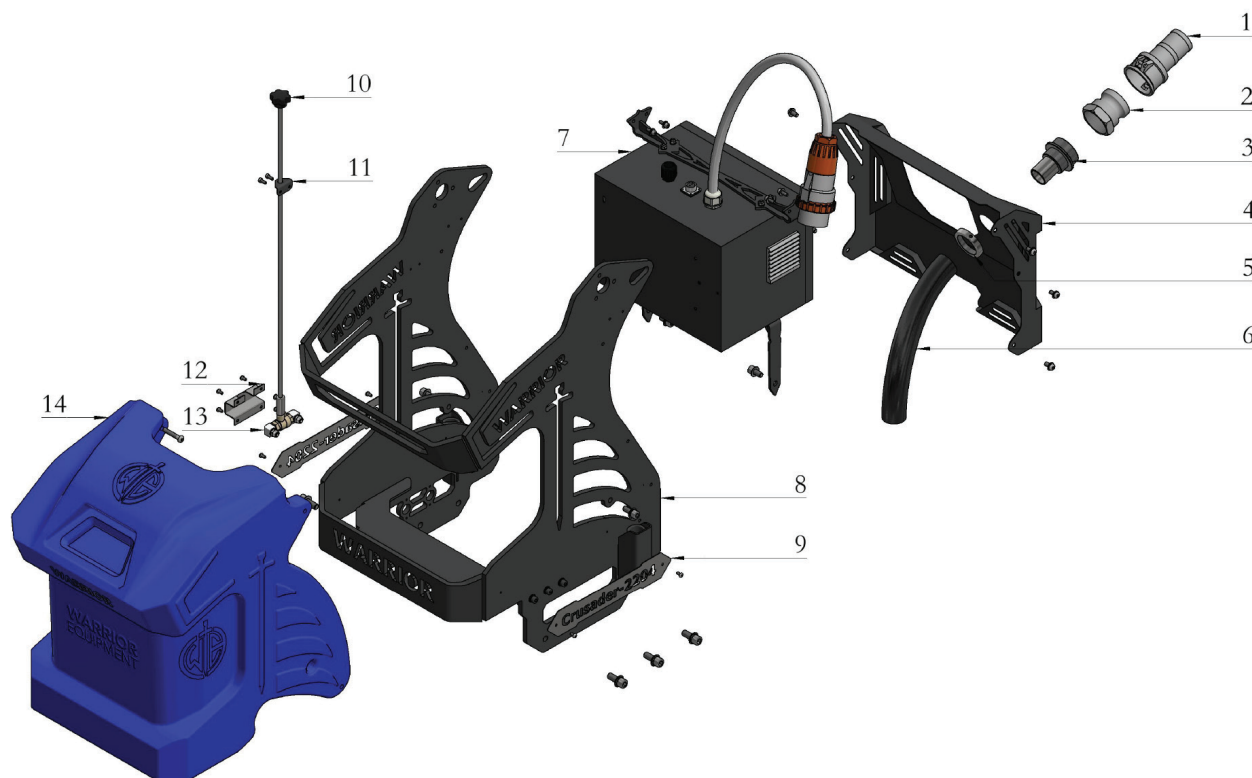
WE-2204 EXPLOSION

NO	NAME	QUANTITY
NO 1	Camlock	1
NO 2	Camlock Connector	1
NO 3	Dust Connector Base	1
NO 4	Motor Protected Plate	1
NO 5	Connector Base Screws	0.5m
NO 6	Dust Tube	1
NO 7	Electrical Box Assem.	1
NO 8	Grinding Machine Frame	2
NO 9	LOGO Plate	1
NO 10	Water Valve Button	1
NO 11	Connector Fixed Plate	1
NO 12	Water Valve Snap Joint	2
NO 13	Water Valve	1
NO 14	Water Tank	

WE-2204 ELECTRICAL BOX EXPLOSION

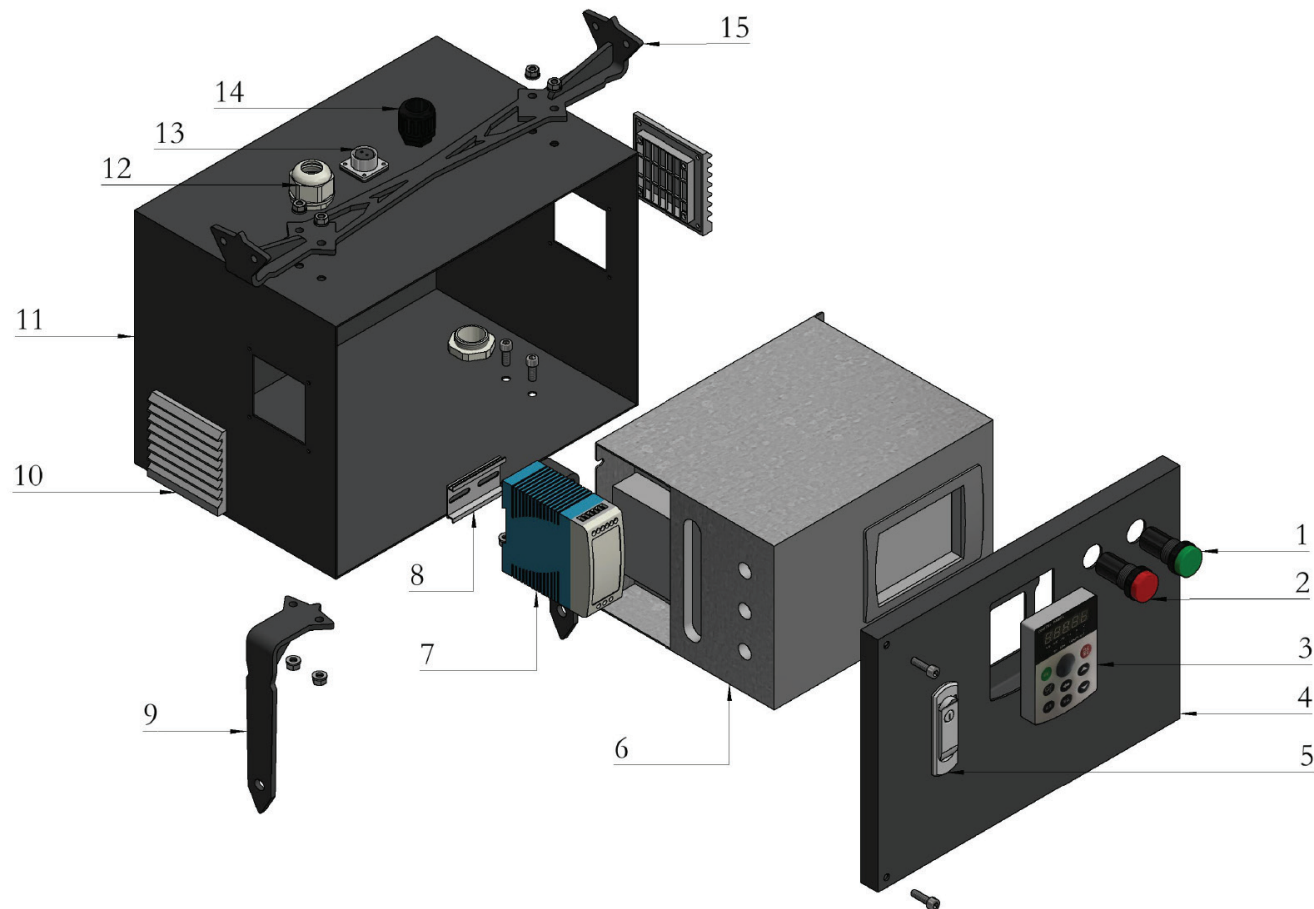

NO	NAME	QUANTITY
NO 1	Working Indication Light (Green)	1
NO 2	Power Indication Light (Red)	1
NO 3	Inverter Panel	1
NO 4	Electrical Box Plate	1
NO 5	Electrical Box Lock	1
NO 6	Inverter	1
NO 7	Power Switch	1
NO 8	Machine Frame	1
NO 9	Electrical Box Support base Frame	2
NO 10	Ventilation Filter Net	2
NO 11	Electrical Box Body	1
NO 12	Input Cable Connector	1
NO 13	LED Light Socket	1
NO 14	Operation Cable Connector	1
NO 15	Electrical Box Support TopFrame	1

WE-2204 GEAR BOX EXPLOSION

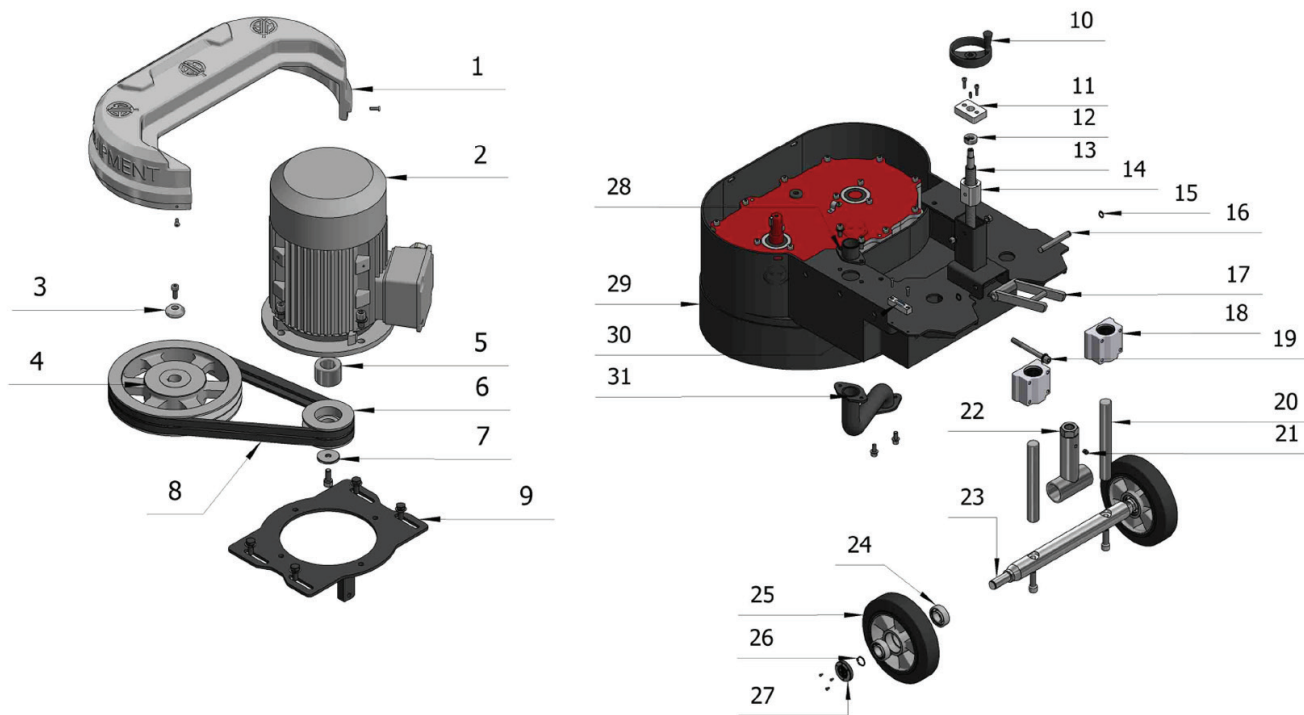

NO	NAME	QUANTITY
NO 1	Gear Box Cover	1
NO 2	Motor	1
NO 3	Belt Pulley Plug	1
NO 4	Belt Pulley ϕ 250	1
NO 5	Motor Crankshaft Sleeve	1
NO 6	Belt Pulley ϕ 97	1
NO 7	Motor Plug	1
NO 8	Belt	1
NO 9	Motor Flange	1
NO 10	Lifting Handle	1
NO 11	Lifting Basement	1
NO 12	Bearing/51102	1
NO 13	Lifting Screw Rod	1
NO 14	Lifting Basement	1
NO 15	Axis Lock ϕ 12	2
NO 16	Shaft	1
NO 17	Support frame	1
NO 18	Slide Bearing	2
NO 19	Inner Hexagon Screw/M10	1
NO 20	Slide Shaft	2
NO 21	Screw Rod Oil Plug	1
NO 22	Screw Rod Cover	1
NO 23	Wheel Shaft	1
NO 24	Bearing/6204	4
NO 25	Moving Wheel	2
NO 26	Axis Lock ϕ 20	2
NO 27	Dust Cover	2
NO 28	Dust Tube -Up	1
NO 29	Gear Box Cover	1
NO 30	Spirit Level	1
NO 31	Dust Tube -Down	1

WE-2204 GEAR BOX EXPLOSION

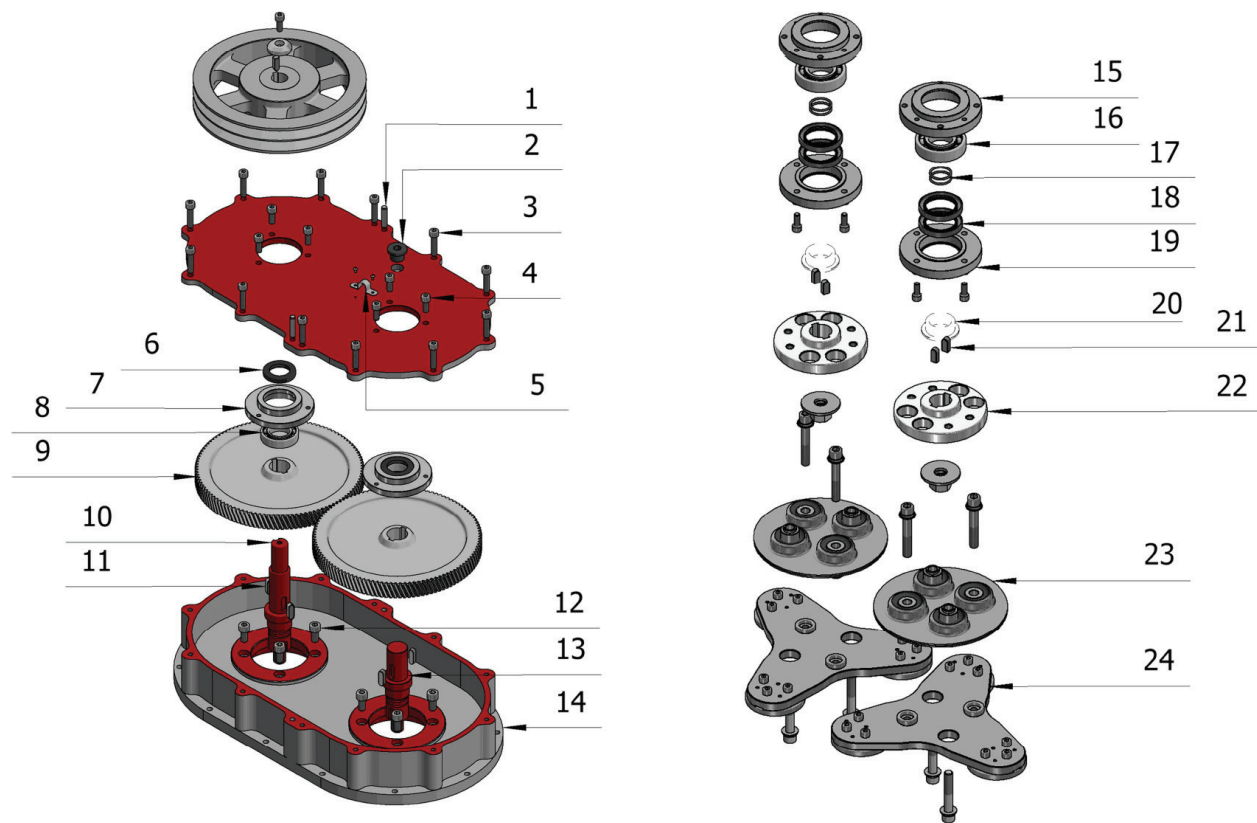

NO	NAME	QUANTITY
NO 1	Pinφ8*35	2
NO 2	Oil Whole Plug	1
NO 3	Inner Hexagon Screw M8*35	12
NO 4	Inner Hexagon Screw M8*20	6
NO 5	Water Tube Clamp φ12	1
NO 6	Oil Seal 30*47*7	2
NO 7	Bearing Basement 6006	2
NO 8	Bearing 6006	2
NO 9	Z112 Gear	1 right, 1 left
NO 10	Main Shaft	1
NO 11	Pin 8*7*25	4
NO 12	Inner Hexagon Screw M10*20	8
NO 13	Second Shaft	1
NO 14	Gear Box Body	1
NO 15	Bearing Basement 6207	2
NO 16	Bearing 6207	2
NO 17	O Ring	4
NO 18	Oil Seal 42*62*7	4
NO 19	Down Basement Cover 6207	2
NO 20	Steel Ring	2
NO 21	Pin 10*8*20	4
NO 22	Grinding Plate Fixed Basement	2
NO 23	Rubber	2
NO 24	Grinding Plate Assem.	2

WE-2204 GEAR BOX EXPLOSION

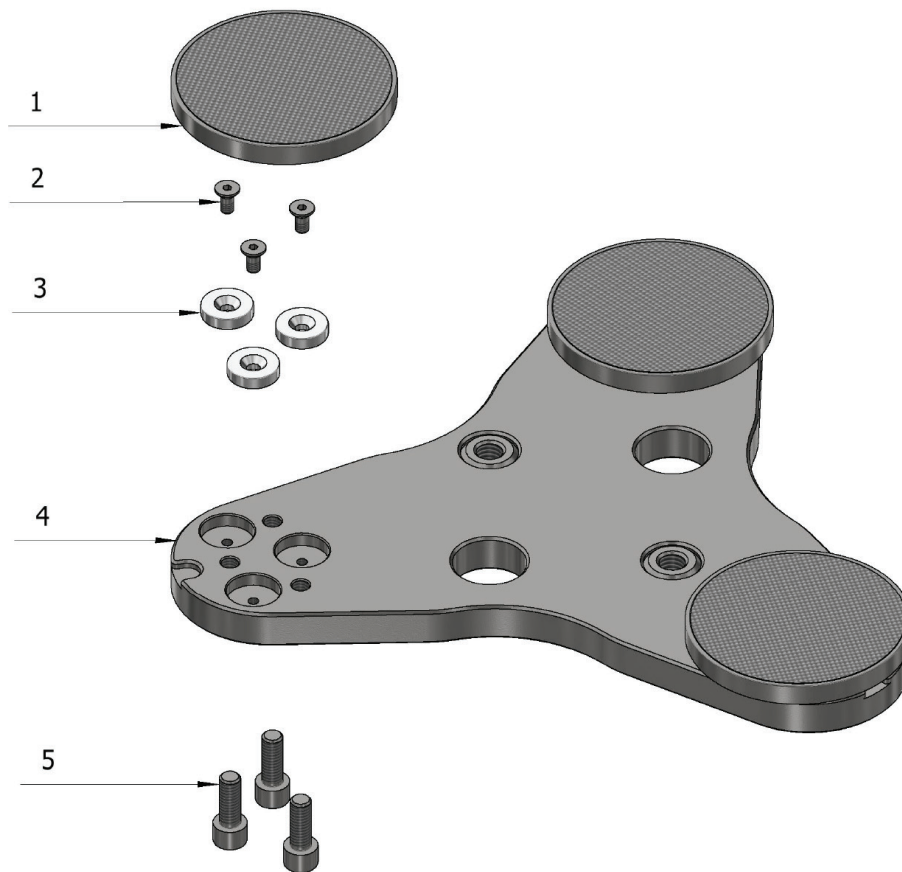

NO	NAME	QUANTITY
NO 1	Velcro	6
NO 2	Inner Hexagon Screw M5*10	18
NO 3	Magnetic Steel	18
NO 4	Grinding Plate	2
NO 5	Inner Hexagon Screw M8*20	18

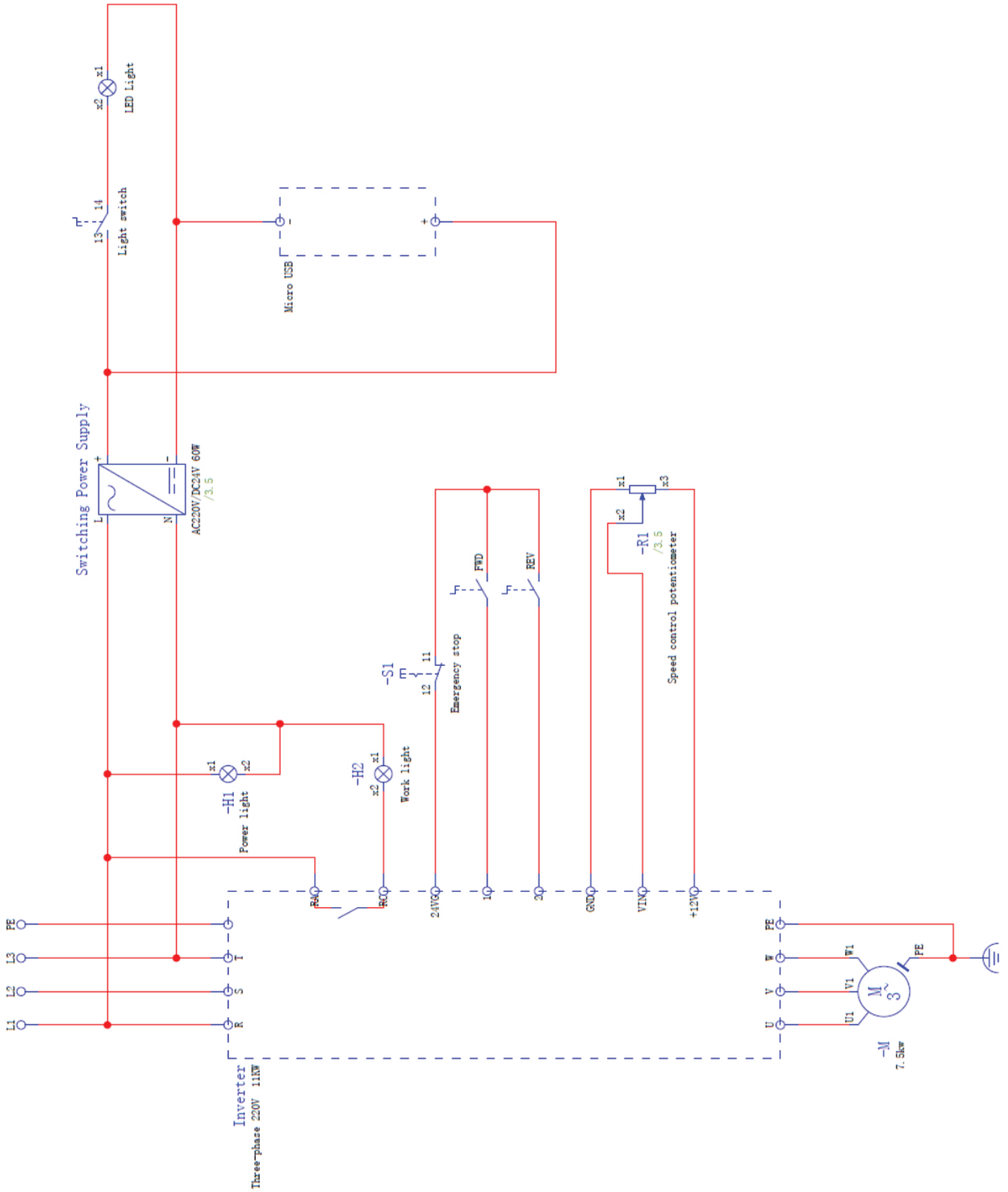
7. ELECTRICAL SCHEMATICS CRUSADER WE-2204

8. WARRANTY

Warrior Equipment warrants, from the time of delivery and receipt by the original customer, new and unused equipment sold by Warrior Equipment or Warrior Equipment distributors. Goods shall be free from defect in workmanship and materials. Motor, Gearbox Gears, and VFD Inverter are covered for a period of 1 year or 300 hours, whichever comes first. If the product does not function satisfactorily during this period, Warrior Equipment will return the product to full working order for normal use which the product is intended for, with no charge for labor or spare parts, according to the following conditions:

1. The warranty only applies to persons that have legal right to the equipment during the warranty period.
2. The manufacturer's undertaking is limited to the repair of defective parts or the replacement of these according to the manufacturer's assessment. Costs and risks for transport as well as dismantling and reinstallation of the product / products and other direct or indirect costs, associated with the repair in question, are not covered by this warranty.
3. Periodic inspections, adjustments, maintenance work and changes are not covered by the warranty.
4. Warrior Equipment is not liable for any damages to grinding discs or other similar equipment.
5. The warranty only applies to material and design deficiencies and does not apply in the following cases:
 - Damage caused through accidents, carelessness, changes, use of spare parts or grinding tools that are not original components, or incorrect use and installation.
 - Damage caused by lightning, water, fire, vandalism, incorrect mains voltage, incorrect ventilation or other causes that lie outside of the manufacturer's control.
 - Unclaimed Damage caused during shipping. All shipments are insured by the shipper until the receiver signs freight companies release paper. Be sure to inspect before signing. If damaged mark clearly on paper and call us immediately.
6. Warrior Equipment reserves the right to modify the design or make improvements without obligation to change previously manufactured products.
7. All warranty repairs must be carried out by Warrior Equipment or by a Warrior Equipment accredited repair workshop. Costs for repairs, carried out by an unauthorized workshop, will not be reimbursed by Warrior Equipment. If such repairs damage this product these are not cover by the warranty agreement.
8. Warrior Equipment will not be liable for shipping / transportation cost for repairs.
9. See Warrior Care for extended warranty coverage.

9. CONTACT US

Warrior Equipment, a division of Incredible Products, LLC • 1101 Lincoln Ave., Wapakoneta, Ohio 45895 • Office Contact # 1-877-743-9732